

Product Information

AllroundLine Z100 up to Z150 SN/SW and Z250 SW materials testing machines

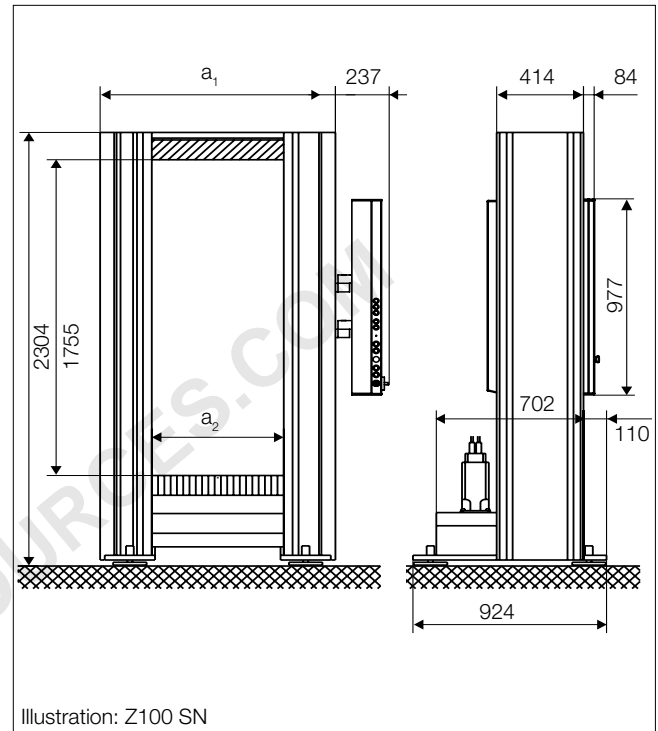

Illustration: Z100 SN

General advantages of AllroundLine with Zwick testControl II electronics

Modern load-frame design

- Drive is via maintenance-free, digitally controlled AC drive technology, which in combination with the innovative motor feedback system ensures excellent constant velocity properties, even at very low speeds.
- Mechanical connections with large mating surfaces and robustly dimensioned components ensure a high level of machine stiffness, which in combination with precise crosshead guidance minimizes undesirable mechanical influences on the specimen.

High level of operator convenience

- Ergonomics are top priority when it comes to operating the new AllroundLine machine.
- Adjustable for optimum ergonomic configuration; modular design allows adaptation as and when required.
- Adjustable crossheads allow variable test area configuration.
- Base design features damping elements with leveling facility plus space for lift truck access - easily adapted to suit the installation site.

Innovative electronics

The new testControl II measurement and control electronics provide the ideal basis for precise, reproducible test results. Impressive features include new drive technology, high measured-value acquisition-rates and a high level of modularity (full details on Page 2).

Highest safety standards

The statutory safety requirements of the EC Machinery Directive are implemented in all AllroundLine machines, which then receive the EC Declaration of Conformity. Only the latest safety technologies and proven industrial components are used. A very high level of safety is guaranteed for user, test results, specimen material and testing system.

Future-proof

Modular design means that the testing system can be re-equipped or upgraded whenever required. Moreover, the testControl II control electronics are compatible with the future generation of Zwick software, with spare parts available for a minimum of ten years after the product has been discontinued.

Product Information

AllroundLine Z100 up to Z150 SN/SW and Z250 SW materials testing machines

Data	Value
Load frame	
Finish	RAL 7021 black grey and RAL 7038 agate grey
Ambient temperature	+10 ... +35 °C
Air humidity (non-condensing)	20 ... 90 %
Drive system	
Motor	AC servo-motor with concentrated windings Hiperface® motor feedback system
Motor holding brake	yes
Input signal, set-value preset	digital (real-time Ethernet, EtherCAT®)
Controller / Cycle time	adaptive / 1000 Hz
Positioning, repetition accuracy on the crosshead	± 2 µm
Measurement and control electronics	
Number of slots available for measurement and control modules	2 synchronized module bus slots (expandable to 5)* 1 synchronised PCIe slot
Force measurement	grade 0.5 / 1 see load cell, to DIN EN ISO 7500-1, ASTM E4,
Calculated resolution (for example in tensile / compression direction)	24 bits
Data acquisition rate, internal	400 kHz
Test data transmission rate to the PC	500 Hz (optional 2000 Hz)
Zero-point correction	automatically at measurement begin
Measurement signal runtime correction for all channels	yes
Interface for PC	Ethernet
Eco Mode	yes, power section automatically switched off (time adjustable)
CE conformity	yes, according to machine guidelines 2006/42/EG
Power ratings	
Mains frequency	50/60 Hz
Electrical connections	400V +/-10% (3Ph, N, PE)

* A high-quality DCSC measurement module for a load cell is included in delivery (occupies one module bus slot).

testControl II - options, e.g.

Description	Item number
Option testControl II plus: Expansion of electronics to 6 slots.	1008208
2000 Hz Online test data transmission: Increasing the test data transmission from 500 Hz (standard) to 2000 Hz. The test data is transmitted to testXpert II, and is processed in real-time.	057860
Display remote control for testControl II for effective, ergonomic operation of the materials testing machine	057984

Options on request, e.g.

- Supplementary crossheads for the additional second test area
- CE-compliant electrically lockable safety device
- Mounting platforms

Product Information

AllroundLine Z100 up to Z150 SN/SW and Z250 SW materials testing machines

Type	Z100 SN	Z100 SW	Z150 SN	Z150 SW	Z250 SW	
Item number	1004504	1004505	1004507	1004509	1004512	
Load frame						
Test load F_N in tensile / compression direction	100	100/50 ⁽¹⁾	150	150/100 ⁽¹⁾	250/100 ⁽¹⁾	kN
Height	2304	2304	2304	2304	2304	mm
Width (a_1)	1123	1523	1123	1523	1523	mm
Width with electronics console	1360	1760	1360	1760	1760	mm
Depth	924	924	924	924	924	mm
Test area width ⁽²⁾ (a_2)	630	1030	630	1030	1030	mm
Test area height ⁽³⁾						
1st size: upper, crosshead top	1755	1720	1675	1615	1615	mm
2nd size: lower, crosshead top	1825	1760	1715	1655	1655	mm
3rd size: lower, crossh. bottom	1820	1755	1655	1595	1595	mm
4th size: upper & lower, with additional crosshead	1735	1645	1540	1440	1440	mm
Overall weight with electronics	1070	1570	1470	2100	2100	kg
Noise level at maximum test speed	70	70	70	70	70	dB (A)
Drive system						
Crosshead speed up to 110% of test load ($v_{min} \dots v_{Nom}$)	0.00005 ... 1000	0.00005 ... 1000	0.00005 ... 900	0.00005 ... 900	0.00005 ... 600	mm/min
Increased crosshead return speed (at reduced force)	1500	1500	1500	1500	1000	mm/min
Drive system's travel resolution	0.31931	0.31931	0.28795	0.28795	0.19227	nm
Power ratings						
Power rating	5	5	5.5	5.5	6	kVA

⁽¹⁾ This testing machine includes two additional test axes (see picture below). The second value indicates the limited test load when testing in the additional test axes.

⁽²⁾ Test area width: the daylight between the side panels.

⁽³⁾ Test area height: the max. distance of the moving crosshead to the upper, i.e. lower crosshead, without any mountings.

⁽²⁾⁽³⁾ A description to these dimensions on next page.

Optional, e.g.:

Supplementary adjustable crossheads

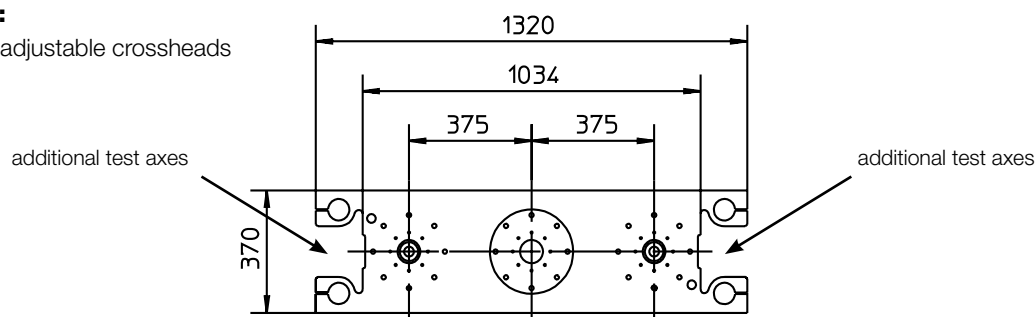

Product Information

AllroundLine Z100 up to Z150 SN/SW and Z250 SW materials testing machines

Maximum travel of the moving crosshead

The *maximum travel s* of the *moving crosshead* is the difference of the test area height P (1st up to 4th size, see table „technical data“) and the sum of the mounting dimensions (E) of the complete testing equipment E: $s = P - E$

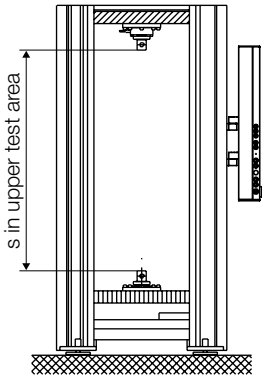

Basic version

Adjustable crosshead above moving crosshead

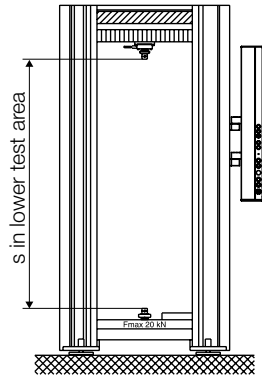

Basic version

Adjustable crosshead above moving crosshead (Fmax restricted)

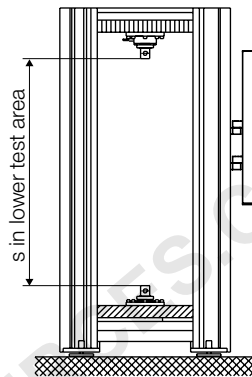

Mounting variant

Mounting of existing adjustable crosshead below moving crosshead

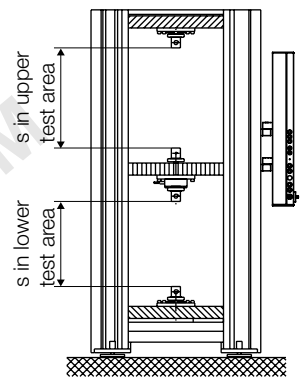

Equipped with additional crosshead

Mounting of additional crosshead/mounting platform

(upper test area)
 $s = 1\text{st size} - E$



(lower test area)
 $s = 2\text{nd size} - E$

(lower test area)
 $s = 3\text{rd size} - E$

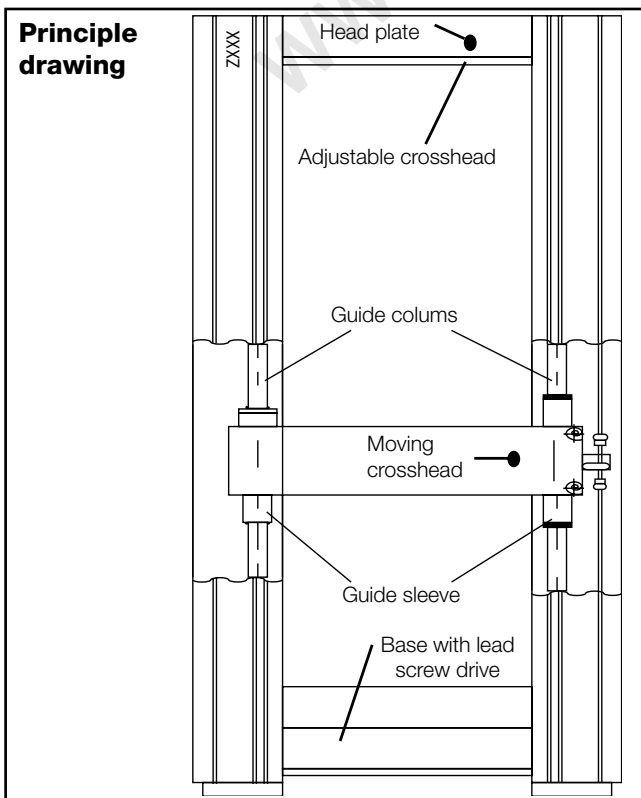
(upper resp. lower test area)
 $s = 4\text{th size} - E$



Legend

-  Adjustable crosshead
-  Moving crosshead
-  Additional, adjustable crosshead / mounting platform