

Type TA Load Cell

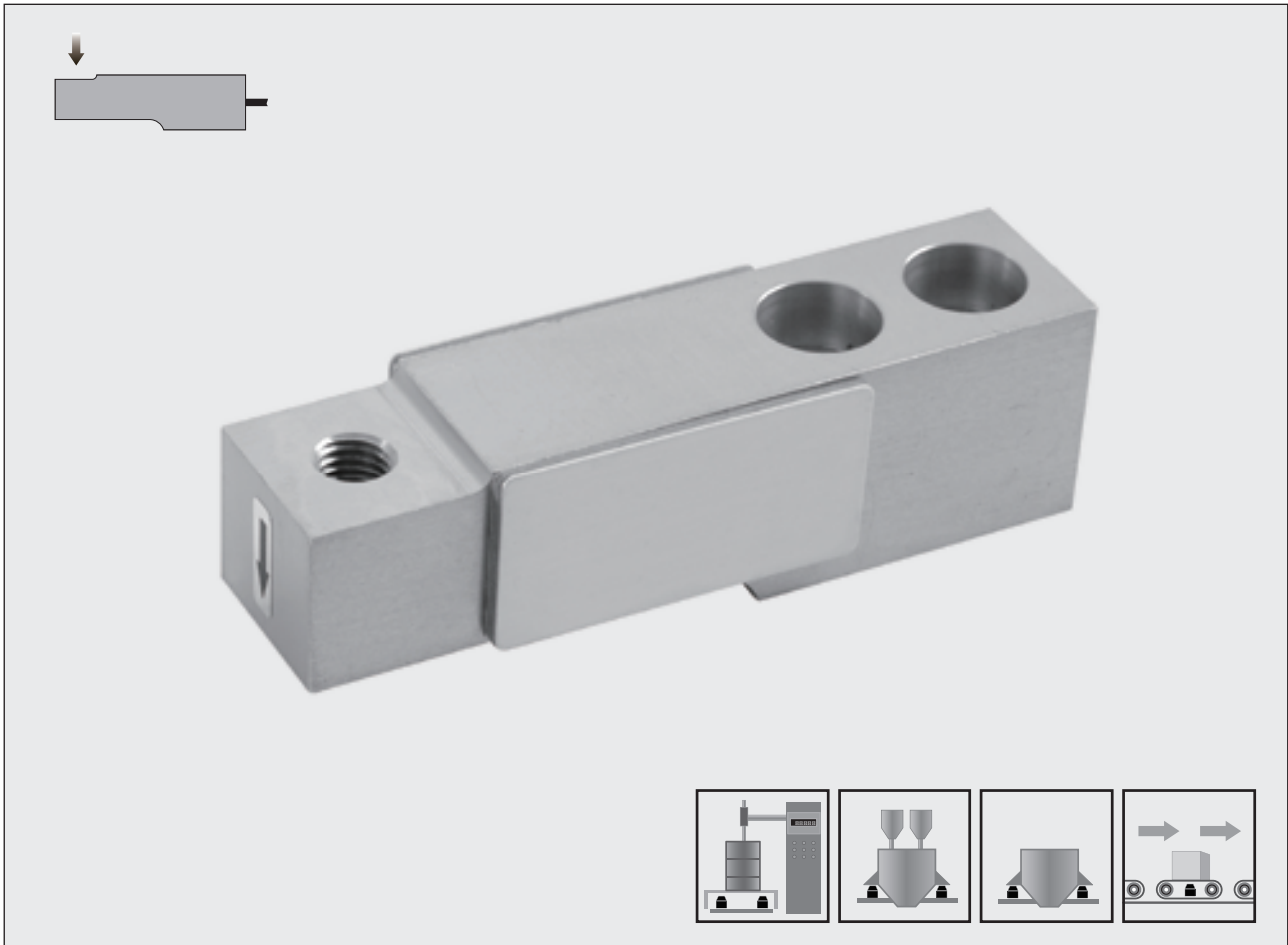

Features 主要特点

- Single ended shear beam load cell
- Senior aluminum
- High accuracy
- High stability
- Easy to install
- Suitable for hopper scales, tank & bin weighing, belt scales, etc.
- 悬臂梁式
- 优质铝合金材质
- 高精度
- 高稳定性
- 安装简便、快速
- 适用于料斗秤、罐装秤、皮带秤等

Schematic 接线方式

- | | | | |
|---------|----------|------|------|
| Red : | + input | 红色 : | + 激励 |
| Black : | - input | 黑色 : | - 激励 |
| Green : | + output | 绿色 : | + 信号 |
| White : | - output | 白色 : | - 信号 |

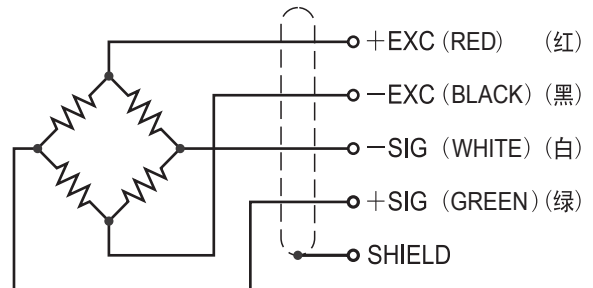

Capacities 量程

- 50kg, 100kg, 150kg, 200kg, 250kg, 300kg, 500kg, 600kg, 750kg, 1000kg

Dimensions 尺寸

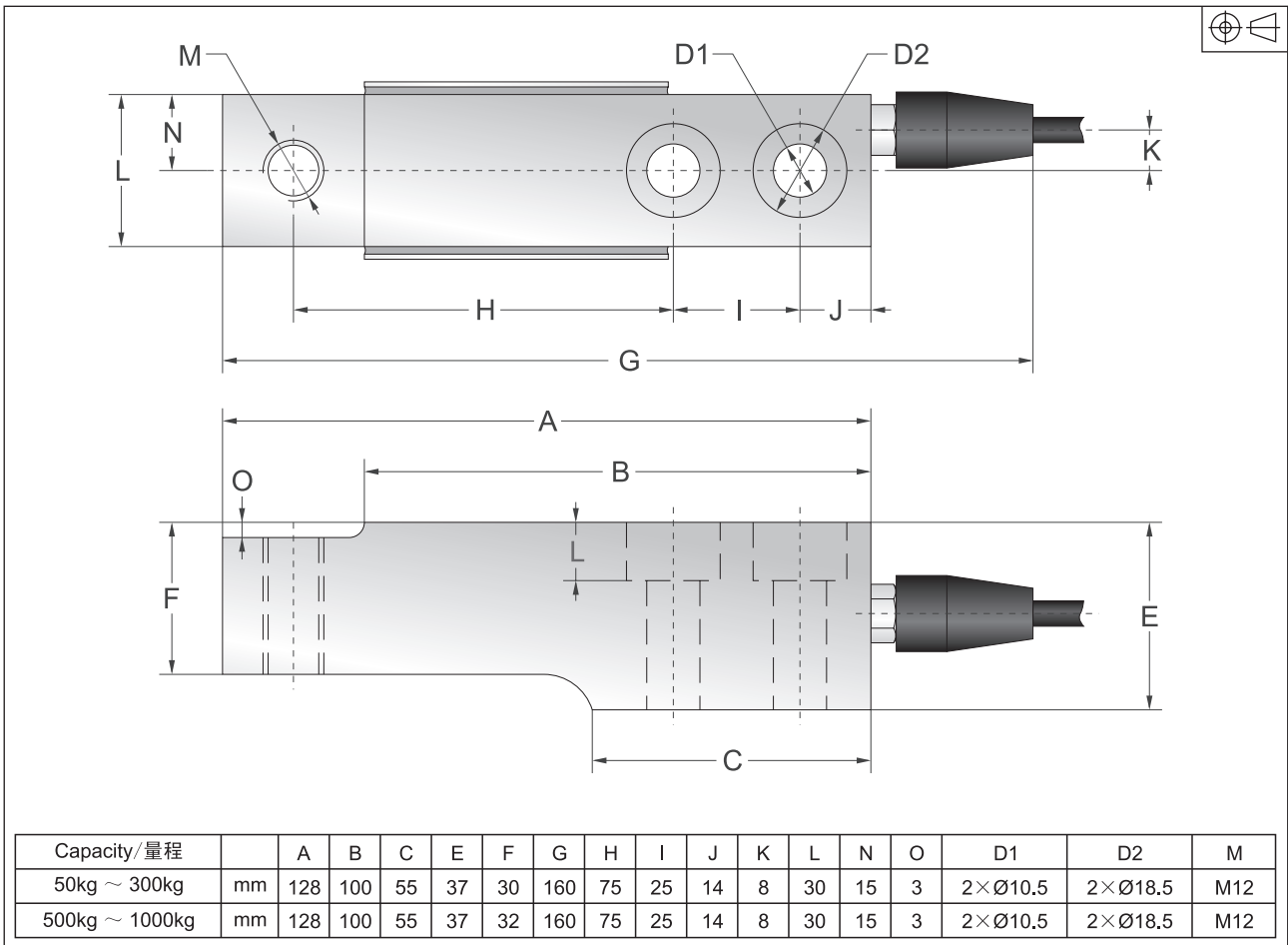

Specification 技术参数

Rated Output	额定输出	2.0mV/V ±1%
Zero Balance	零点平衡	±3% of rated output
Creep after 30 minutes	蠕变	±0.03% of rated output
Nonlinearity	非线性	±0.03% of rated output
Hysteresis	滞后	±0.03% of rated output
Repeatability	重复性	±0.03% of rated output
Temp. effect on output	灵敏度温漂	≤0.002% of applied output/°C
Temp. effect on zero	零点温漂	≤0.002% of rated output/°C
Safe Temp. Range	可用温度范围	-10°C to + 70°C
Temp. Compensated	温度补偿范围	-10°C to + 40°C
Safe Overload	安全载荷	150%
Input Impedance	输入阻抗	410 ohm ± 20 ohm
Output Impedance	输出阻抗	350 ohm ± 5 ohm
Insulation Resistance	绝缘阻抗	≥5000 M ohm (50V DC)
Rated Excitation	推荐激励电压	10V DC/AC
Maximum Excitation	最大激励电压	15V DC/AC
Cable Length	导线长度	275cm
Cable Color Code	导线颜色	Red(+ E) Black(- E) Green(+ S) White(- S)