

T66 Cantilever Beam Load Cell

Capacities: 20 kg 100 kg
 50 kg 200 kg

- Three year warranty
- Fully welded stainless steel construction
- Ideal for use in vessel and hopper weighing applications
- Sealed to IP68 according to EN 60529
- Approved EEx ia IIC T6 according to CENELEC EN 50 020
- Optional M16 conduit adapter to allow direct connection of flexible conduit to enhance cable protection



Junior LoadMount with T66 load cell fitted

Cantilever beam load cells

This fully welded stainless steel load cell is hermetically sealed to IP68 and can be used in the harshest industrial environments. It is suitable for weighing platforms, bag fillers, belt weighers and tank weighing in the food processing, chemical, pharmaceutical and general bulk handling industries.

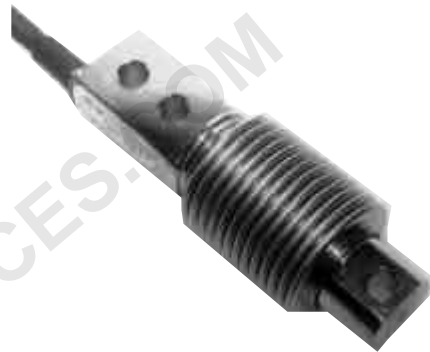

T66 cantilever beam load cell

High integrity cable entry avoids moisture ingress

The cable entry of a load cell is a potentially weak point in its sealing. The cantilever beam design uses a special gland which provides long-term sealing even when exposed to regular washing-down. An optional conduit adapter allows flexible conduit to be connected over the gland for extra mechanical protection.

Certified intrinsically safe

Optional CENELEC EEx ia IIC T6 approval means that these cells can be used in all Zones and classes of hazardous area.

Nova Weigh LoadMount assemblies for simple vessel weighing

The benefits of the cantilever beam load cell are only apparent when used in a mounting assembly specifically designed for vessel weighing. Nova Weigh's range of LoadMount assemblies provides all the features required, including a locked-up assembly for simple installation and integral jacking for load cell insertion and replacement.

LoadMounts are suitable for even the toughest chemical reactor weighing task.

TECHNICAL SPECIFICATION

Performance

Parameter	Units	Accuracy class		
		0.05%	0.03%	C3
Rated output	mV/V $\pm 0.25\%$	2	2	2
Combined error	%*	$< \pm 0.05$	$< \pm 0.03$	
Non-repeatability	%*	$< \pm 0.01$	$< \pm 0.01$	
Creep (30 minutes)	%*	$< \pm 0.03$	$< \pm 0.025$	
Temperature effect on zero balance	%*/°C	$< \pm 0.0025$	$< \pm 0.0015$	
Temperature effect on span	%*/°C	$< \pm 0.005$	$< \pm 0.0015$	
Compensated temperature range	°C	-10 to +40	-10 to +40	
Operating temperature range	°C	-40 to +80	-40 to +80	-40 to +80
Safe overload	%*	150	150	150
Ultimate overload	%*	300	300	300
Zero balance	%*	$< \pm 1$	$< \pm 1$	$< \pm 1$
Input resistance	Ω ± 30	380	380	380
Output resistance	Ω ± 1.5	350	350	350
Insulation resistance	M Ω @ 100 V	> 5000	> 5000	> 5000
Recommended supply voltage	V	10	10	10
Maximum supply voltage	V	15	15	15

*with respect to rated output

Note: For use with zener barriers, load cells with 1000 ohm impedance can be supplied

Cable four core screened, 16/0.2 mm, polyurethane

+ Excitation = Red + Signal = Green
- Excitation = Blue - Signal = Yellow

Dimensions (mm)

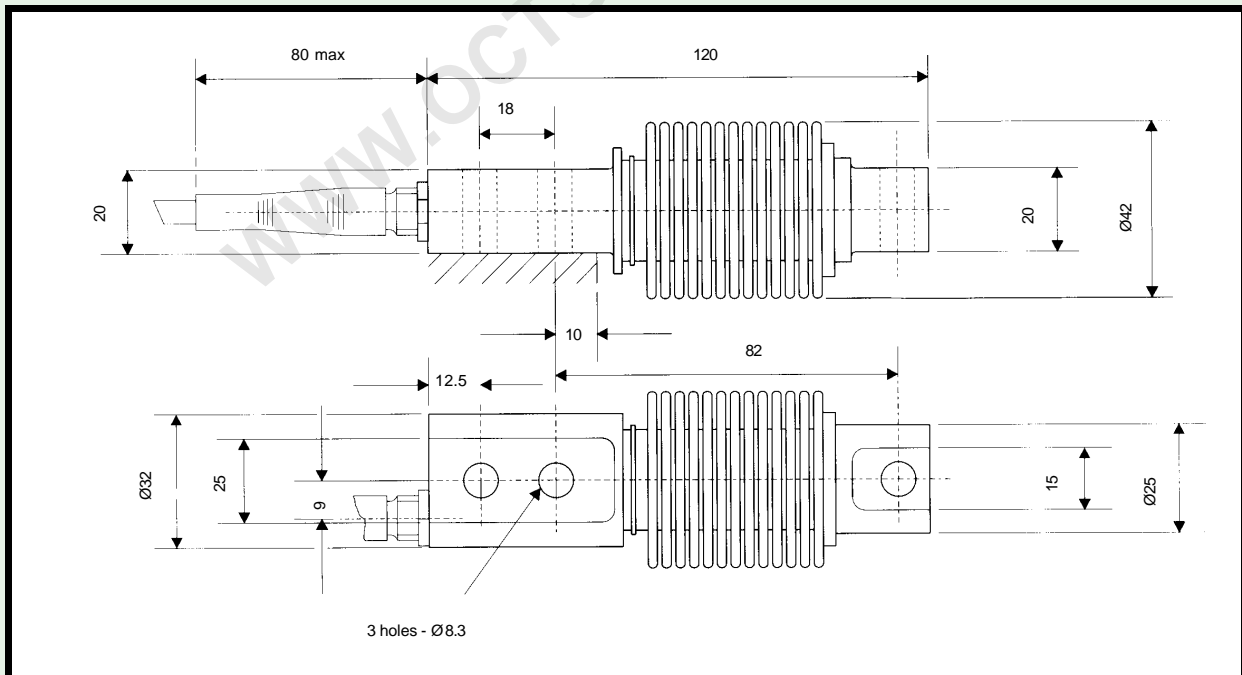

NOVA WEIGH



Nova Weigh's policy of constant product development dictates that we may alter specifications and or the appearance of our product range without notice.